

TECHNICAL DATASHEET

110P MAC

ORDER INFORMATION

Short Code

110P MAC

Quantity per EU/CNT pallet

24/40 pcs

LxWxH (mm)

509x175x182

Lead weight (kg)

19.8

Electrolyte (kg)

11.6

Total Weight (kg)

34.3

TECHNOLOGY

Battery Technology

Flooded

Grid Type (pos/neg)

Casted/Expanded

Grid Alloy (pos/neg)

Sb/Ca

Separator

PE

TECHNICAL INFORMATION

Voltage (V)

12

Capacity C5 (Ah)

110

Capacity C20 (Ah)

125

CCA-18°C EN (A)

850

BOX DESIGN

Box Type

MAC110

Cover Type

Flat

Colour

Black

Polarity

3

Hold down

B0

Terminal

1

DRAWING

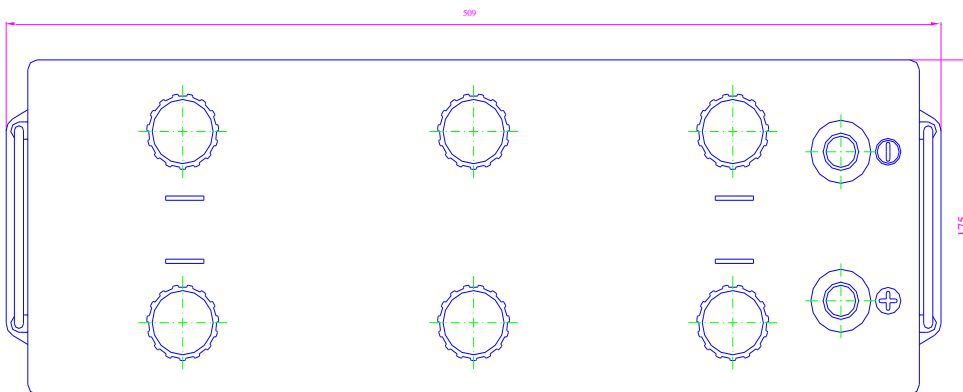
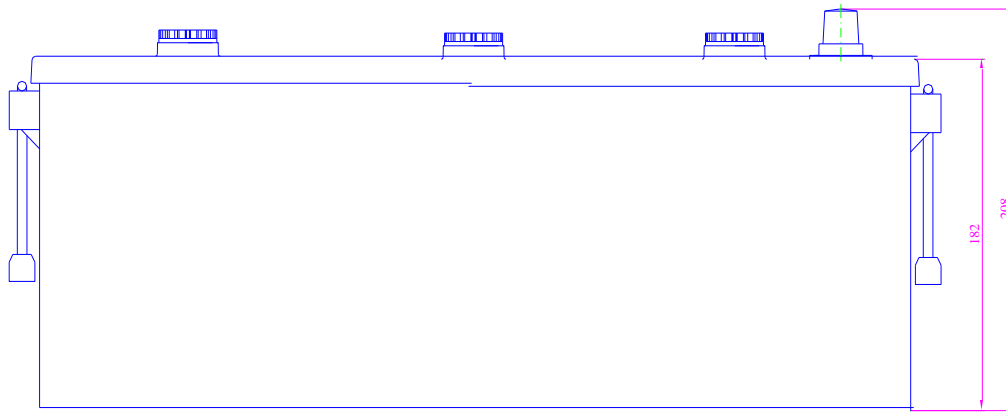

TECHNICAL DATASHEET

110P MAC

TAB d.d, Polena 6, SI-2392 Mežica, Slovenia, www.tab.si