

TECHNICAL DATASHEET

60P

ORDER INFORMATION

Short Code

60P

Quantity per EU/CNT pallet

48/80 pcs

LxWxH (mm)

278x175x190

Lead weight (kg)

11.2

Electrolyte (kg)

6.1

Total Weight (kg)

19.4

TECHNOLOGY

Battery Technology

Flooded

Grid Type (pos/neg)

Expanded/Expanded

Grid Alloy (pos/neg)

Ca/Ca

Separator

PE

TECHNICAL INFORMATION

Voltage (V)

12

Capacity C5 (Ah)

60

Capacity C20 (Ah)

75

CCA-18°C EN (A)

680

BOX DESIGN

Box Type

L3

Cover Type

Kamina

Colour

Black

Polarity

0

Hold down

B13

Terminal

1

DRAWING

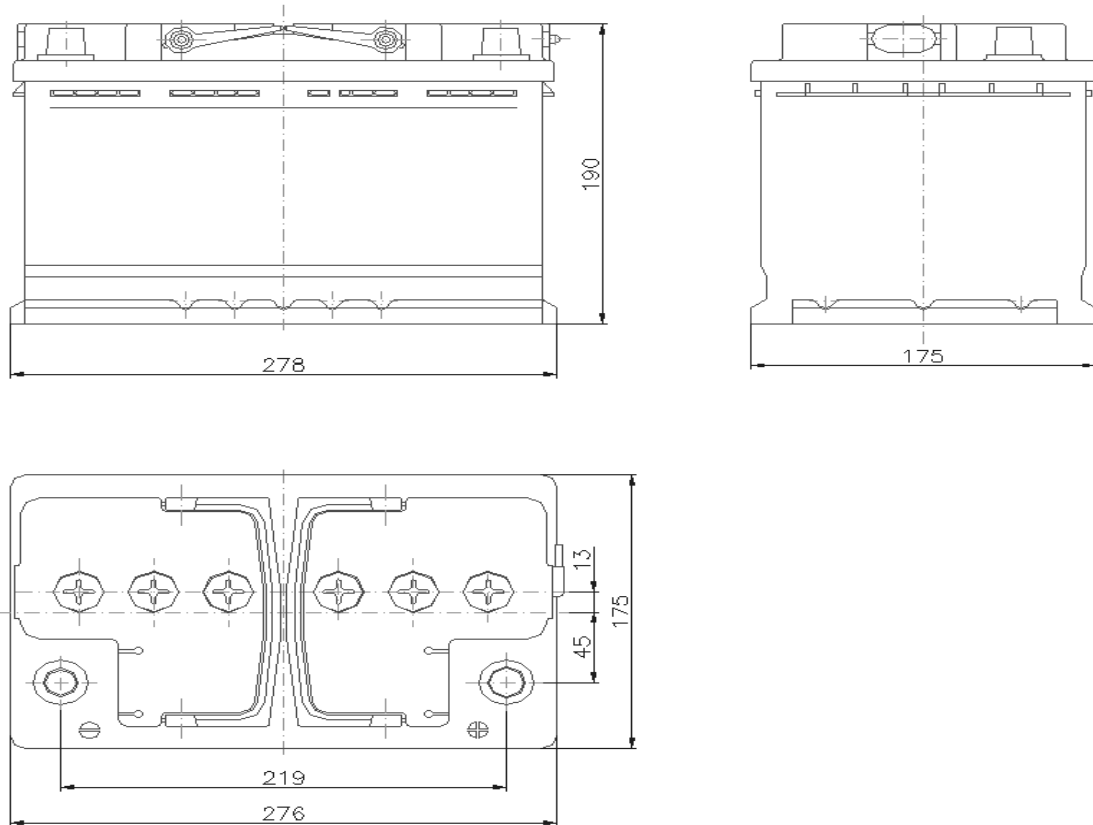

TECHNICAL DATASHEET

60P