

TECHNICAL DATASHEET

80P

ORDER INFORMATION

Short Code

80P

Quantity per EU/CNT pallet

36/60 pcs

LxWxH (mm)

312x175x212

Lead weight (kg)

12.5

Electrolyte (kg)

7.4

Total Weight (kg)

22.3

TECHNOLOGY

Battery Technology

Flooded

Grid Type (pos/neg)

Expanded/Expanded

Grid Alloy (pos/neg)

Ca/Ca

Separator

PE

TECHNICAL INFORMATION

Voltage (V)

12

Capacity C5 (Ah)

80

Capacity C20 (Ah)

105

CCA-18°C EN (A)

760

BOX DESIGN

Box Type

100B

Cover Type

Kamina

Colour

Black

Polarity

0

Hold down

B0

Terminal

1

DRAWING

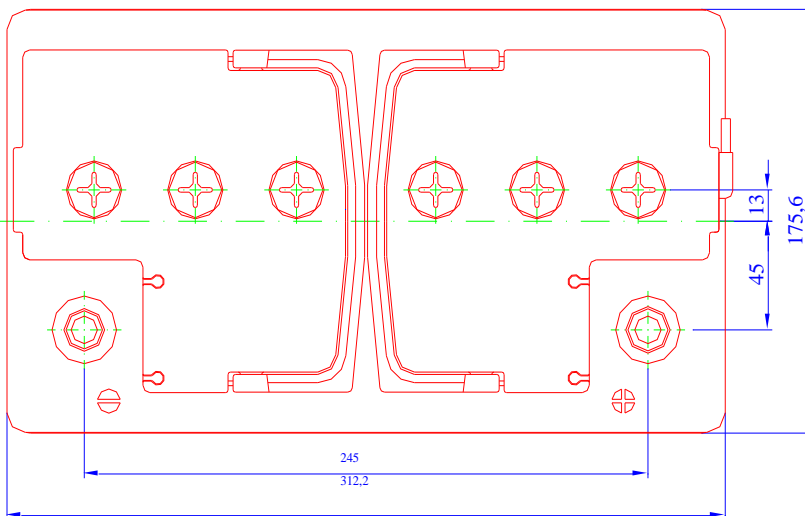
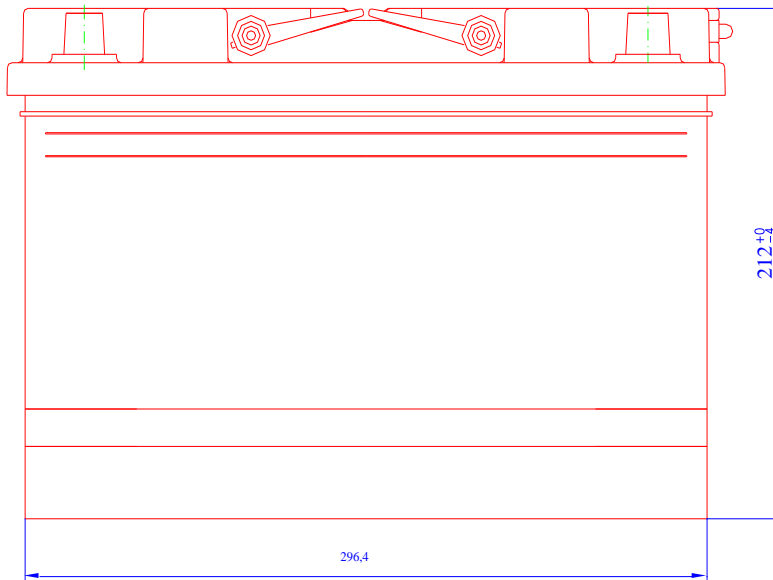

TECHNICAL DATASHEET

80P