



## TECHNICAL DATASHEET

### TAB POLAR S10

#### ORDER INFORMATION

TAB ID

Short Code

**S10**

DIN Marking

**60021 SMF**

Quantity per EU/CNT pallet

**36/72 pcs**

#### TECHNOLOGY

Primary Function

**Engine Start**

Battery Technology

**Flooded**

Grid Type (pos/neg)

**Expanded/Concasted**

Grid Alloy (pos/neg)

**Ca/Ca**

Separator

**PE**

Electrolyte (g/cm<sup>3</sup>)

**1,28**

#### TECHNICAL INFORMATION

Voltage (V)

**12**

Capacity C20 (Ah)

**100**

CCA -18°C EN (A)

**850**

RC (min)

**90**

LxWxH (mm)

**353x175x175**

Total Weight (kg)

**21.1**

#### BOX DESIGN

Box Type

**L5B**

Cover Type

**SMF**

Colour

**Black**

Layout

**0**

BHD

**B13**

Terminal

**1**

## DRAWING

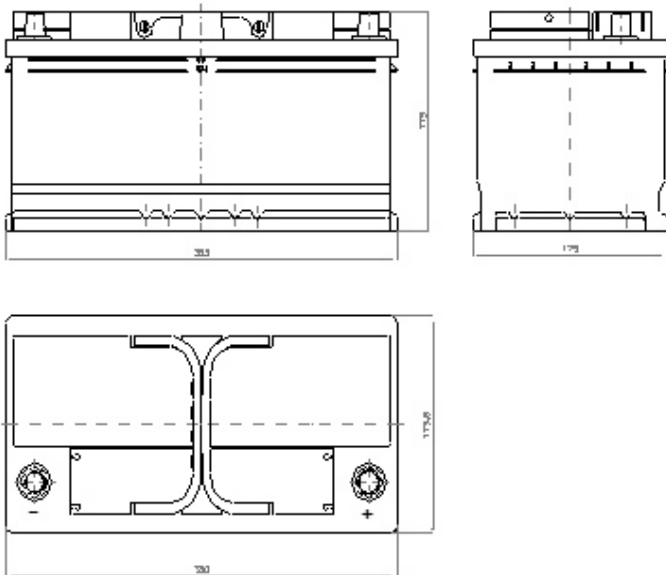

## BHD

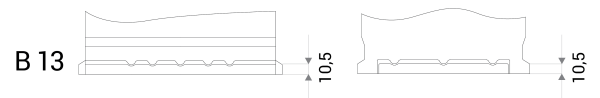

## LAYOUT

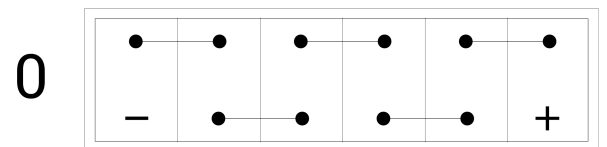

## TERMINAL

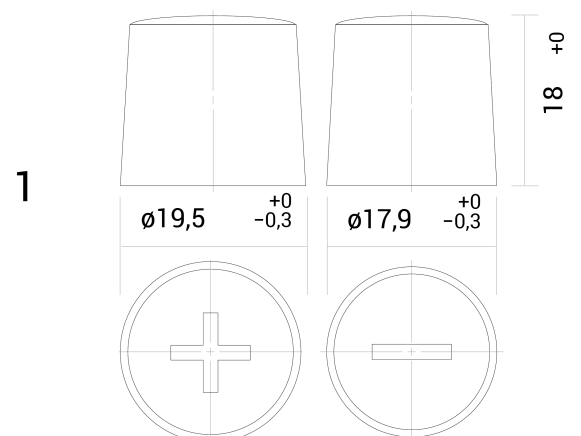

## TECHNICAL DATASHEET

### TAB POLAR S10

TAB d.d, Polena 6, SI-2392 Mežica, Slovenia, [www.tab.si](http://www.tab.si)