



TECHNICAL DATASHEET

TAB POLAR S83

ORDER INFORMATION

TAB ID

Short Code

S83

DIN Marking

58317 SMF

Quantity per EU/CNT pallet

48/80 pcs

TECHNOLOGY

Primary Function

Engine Start

Battery Technology

Flooded

Grid Type (pos/neg)

Expanded/Concasted

Grid Alloy (pos/neg)

Ca/Ca

Separator

PE

Electrolyte (g/cm³)

1,28

TECHNICAL INFORMATION

Voltage (V)

12

Capacity C20 (Ah)

83

CCA -18°C EN (A)

710

RC (min)

90

LxWxH (mm)

278x175x175

Total Weight (kg)

15.9

BOX DESIGN

Box Type

L3B

Cover Type

SMF

Colour

Black

Layout

0

BHD

B13

Terminal

1

DRAWING

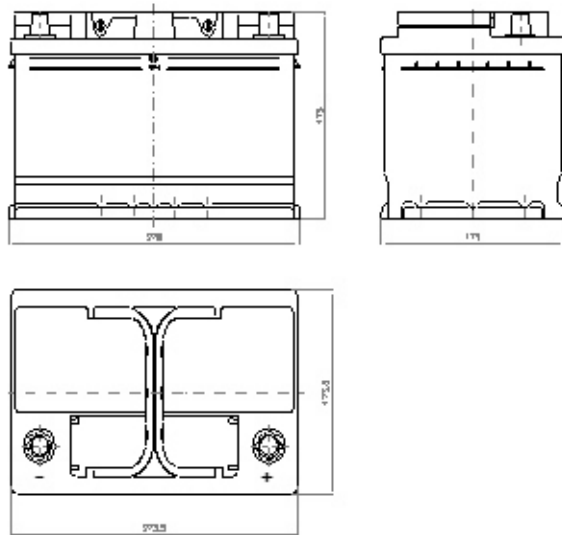

BHD

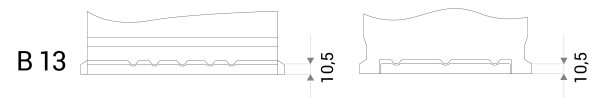

LAYOUT

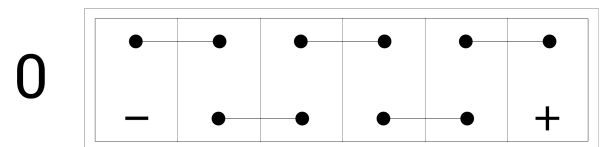

TERMINAL

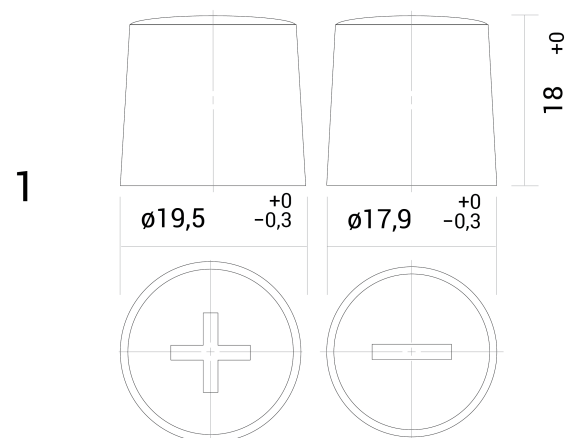

TECHNICAL DATASHEET

TAB POLAR S83

TAB d.d, Polena 6, SI-2392 Mežica, Slovenia, www.tab.si